

KING SIZE 70 V PND



Suspended luminaire with PMMA tube shade. Top quality SMD LED module with colour consistency MacAdams ≤ 3 , extensive portfolio of lumen ranges, CCTs and spectra. Variety of drivers: standard EVG on/off, DALI and wireless controlled as MasterConnect or Casambi on request. Remote, wireless occupancy & daylight sensor available to allow significant energy savings and wireless connectivity. Mounting on any type of ceiling. Body is made of aluminium, steel and PMMA tube. Standard colour RAL 9003S, any other colour from basic RAL range available at no extra cost. Variety of lumen outputs and drivers allows to use this luminaire in different types of lighting projects.

Luminous flux & Luminaire Power tolerance up to 10%. System power consumption depends on components used. Luminous efficacy depends on type of LED's, electronics, optics and diffusor. The most up to date technical parameters can be found on our website and in database of LDT files.

Lighting direction:

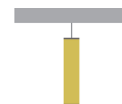

PDF datasheet:



KING SIZE 70 V PND

Mounting:	Suspended
Body material:	Steel and aluminium
Colour:	Standard white RAL 9003S, other RAL colours on request
Lumen output:	Standard up to 4000 lm, any other on request
LED module:	Signify (Philips), Tridonic or equivalent SMD LED module
Colour temperature:	3000/4000K/RGBW, other on request
Colour Rendering:	CRI>80 in standard, other on request
Driver:	EVG on-off/DALI, other on request
Wireless control:	N/A
Daylight/Occupancy sensor:	N/A
Emergency unit:	N/A
Operating temperature range:	0°C ... +35°C
IP Class:	IP20 in standard
Power:	220-240V 50/60Hz
Lighting direction:	Direct, direct / indirect lighting
Light distribution:	Symmetric
Diffuser:	PMMA acrylic tube
Beam angle:	All types available in our LDT file database
Warranty:	5 Years standard warranty

KING SIZE 70 V PND suspended, vertical, ambient lighting

All current index numbers, lumen outputs, power consumption and many other technical information are available in our 2024 pricelist. Details on wireless lighting control systems on page number 896.



Energy saving MasterConnect wireless lighting control system with daylight and movement detection technology on request.

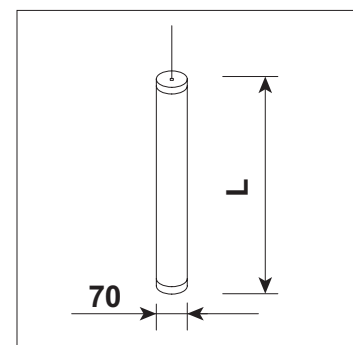

Basic dimensions



KING SIZE 70 V PND

Product code	Product name	Gross Lumen [lm]	Nett Lumen [lm]	Power [W]	Efficacy [lm/W]	Colour temperature [K]	Optics	Length [mm]	Width [mm]	Height [mm]	Nett Weight [kg]
50.02770.83.E.ACT	KING SIZE 70 V PND 8800lm / 830 / E / ACT	8800	6160	52	118	3000	Symmetrical	1190	80	80	2,7
50.02770.84.E.ACT	KING SIZE 70 V PND 8800lm / 840 / E / ACT	8800	6160	52	118	4000	Symmetrical	1190	80	80	2,7